



A Multilink Manipulator with IPMC Joints

Andres Hunt, Andres Punning, Mart Anton, Alvo Aabloo, Maarja Kruusmaa

Intelligent Materials and Systems Laboratory, Institute of Technology, Tartu University, Estonia

Nooruse 1, 50411, Tartu
ahunt@ut.ee, alvo@ut.ee

1. IPMC

Ionic Polymer Metal Composite (class of electroactive polymers, EAP, Fig 1).

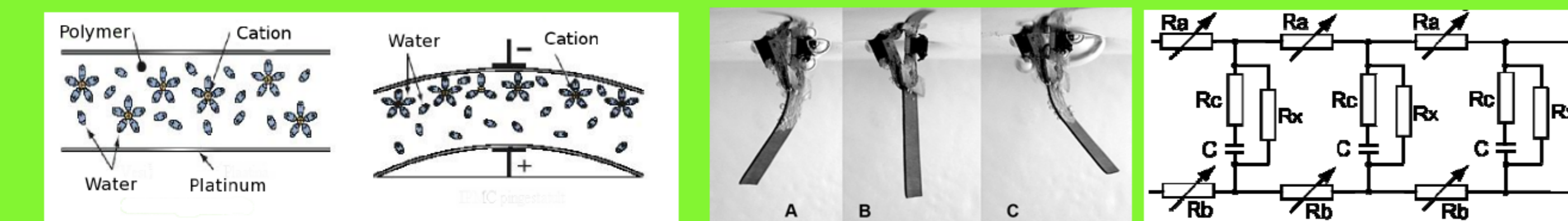

Figure 1. IPMC at rest and with voltage applied (left and middle) and lossy transmission line model of IPMC (right)

2. Material modeling

- IPMC can be modelled as a lossy transmission line (Figure 1).
- Simulations show that there exists a specific length at which curvature is linear in time and space (at about 3mm, Fig 2).
- From mechanical modelling it can be seen that for increasing work done by IPMC per unit area short IPMC should be used.
- It is easier to estimate the shape of IPMC with rigid elongation (Fig 3).

3. Manipulator experiments

Precision multilink manipulator (Fig 4) was built to test the applicability of short IPMC with elongation, measure the precision of the manipulator and compare it to long IPMC.

Experiment phases (setup in Fig 5):

1. Calibrate IPMC joints
2. Test the precision
3. Calibrate long IPMC
4. Test the precision
5. Compare results

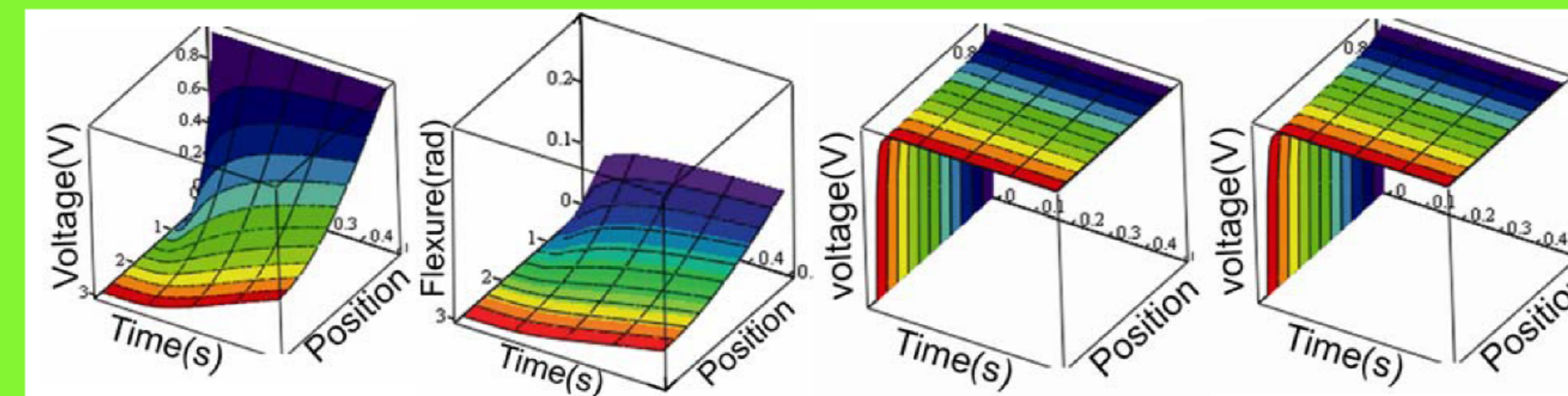

Figure 2. Simulations of IPMC as a lossy transmission line for 30mm (left) and 3mm long strip (right)

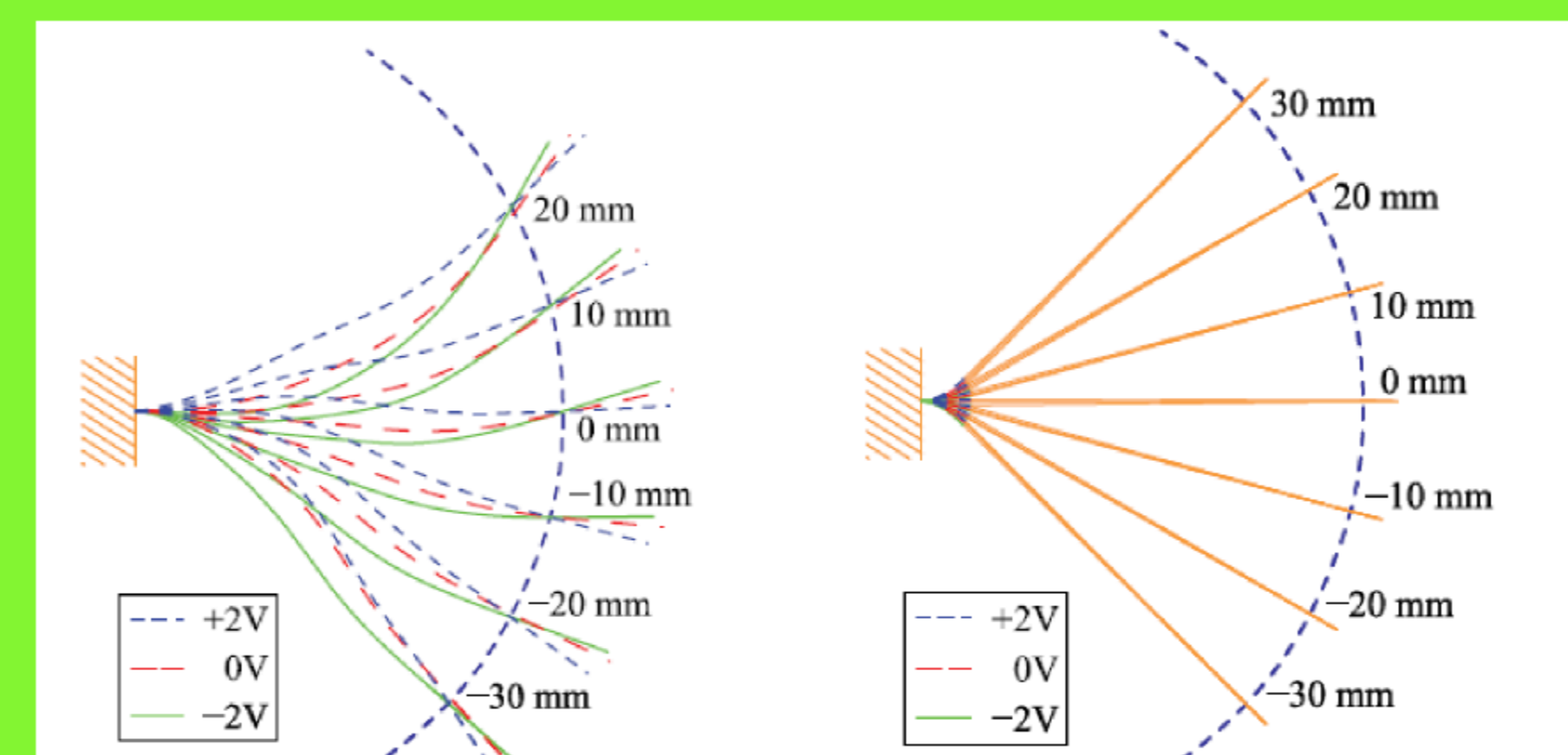

Figure 3. Mechanical modeling of long IPMC and short IPMC with rigid elongation

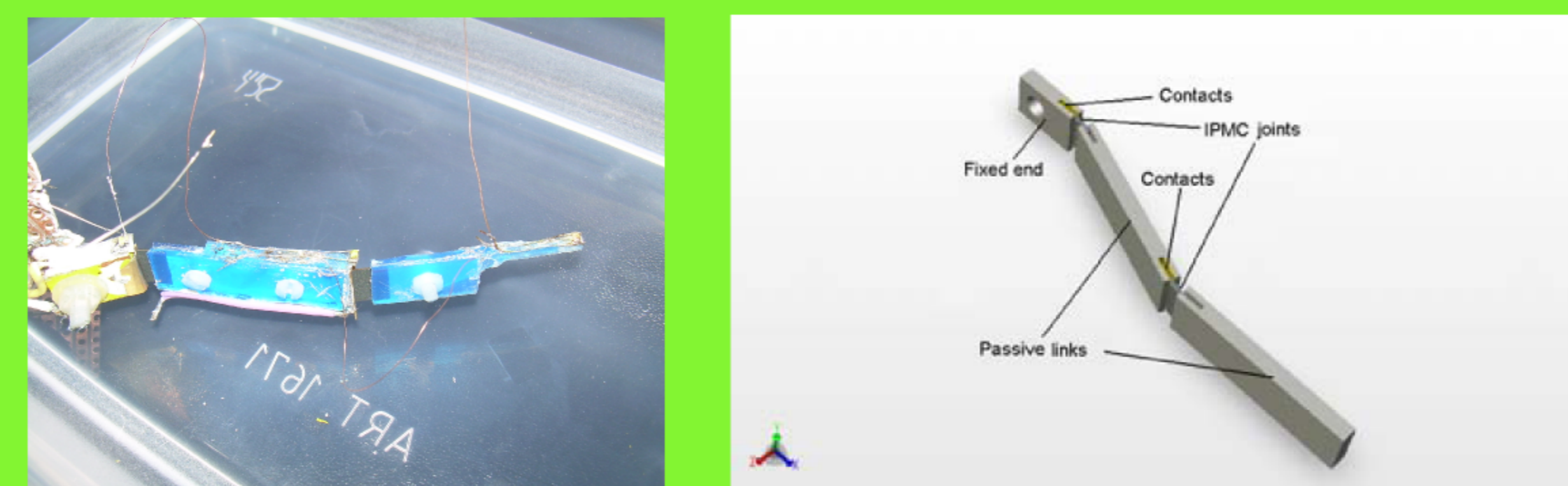

Figure 4. Manipulator

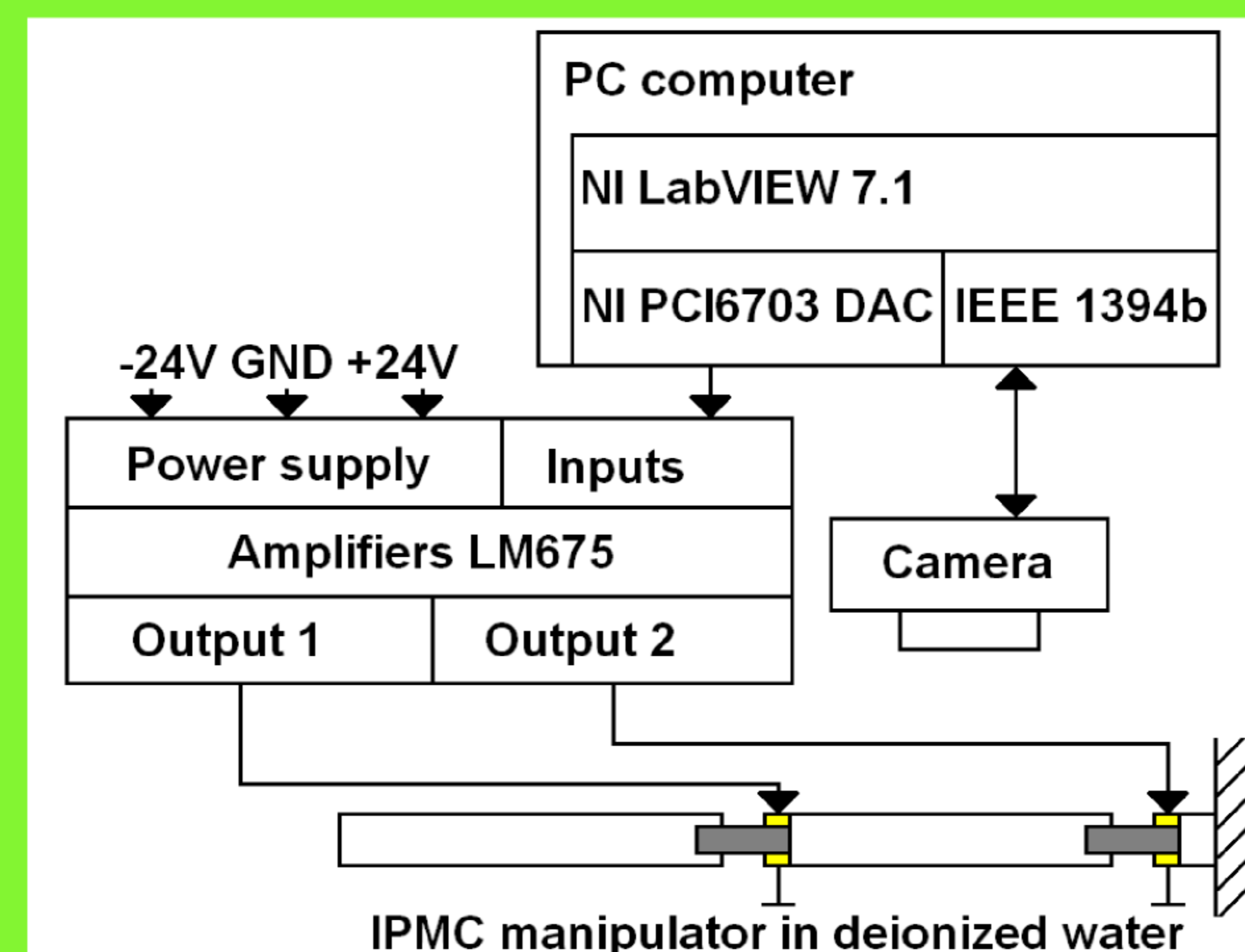

Figure 5. Experiment setup

4. Results

- There exists a length of IPMC active area for IPMC with extension which corresponds to linear relationship between input voltage and output angle at 4mm +/-1mm (Fig 6).
- Manipulator is 314% more accurate than long IPMC (Fig 7).
- Actuation range increases in width as well as in dimensions

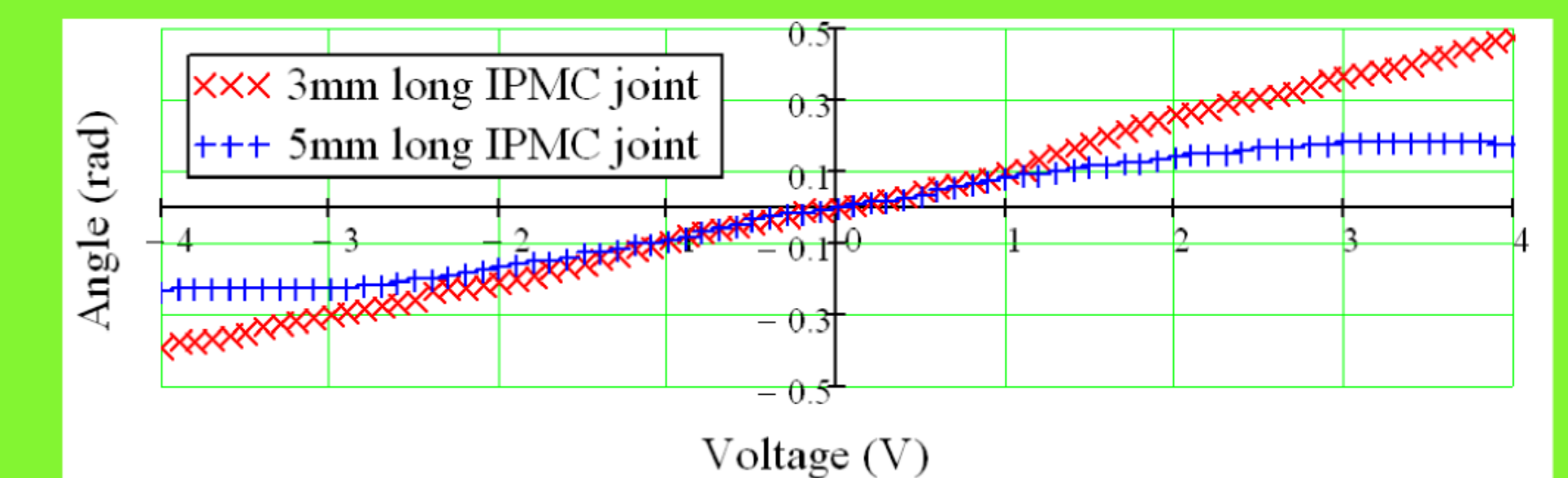

Figure 6. Calibration charts for IPMCs with extension. Optimal and suboptimal length when targeting linear chart

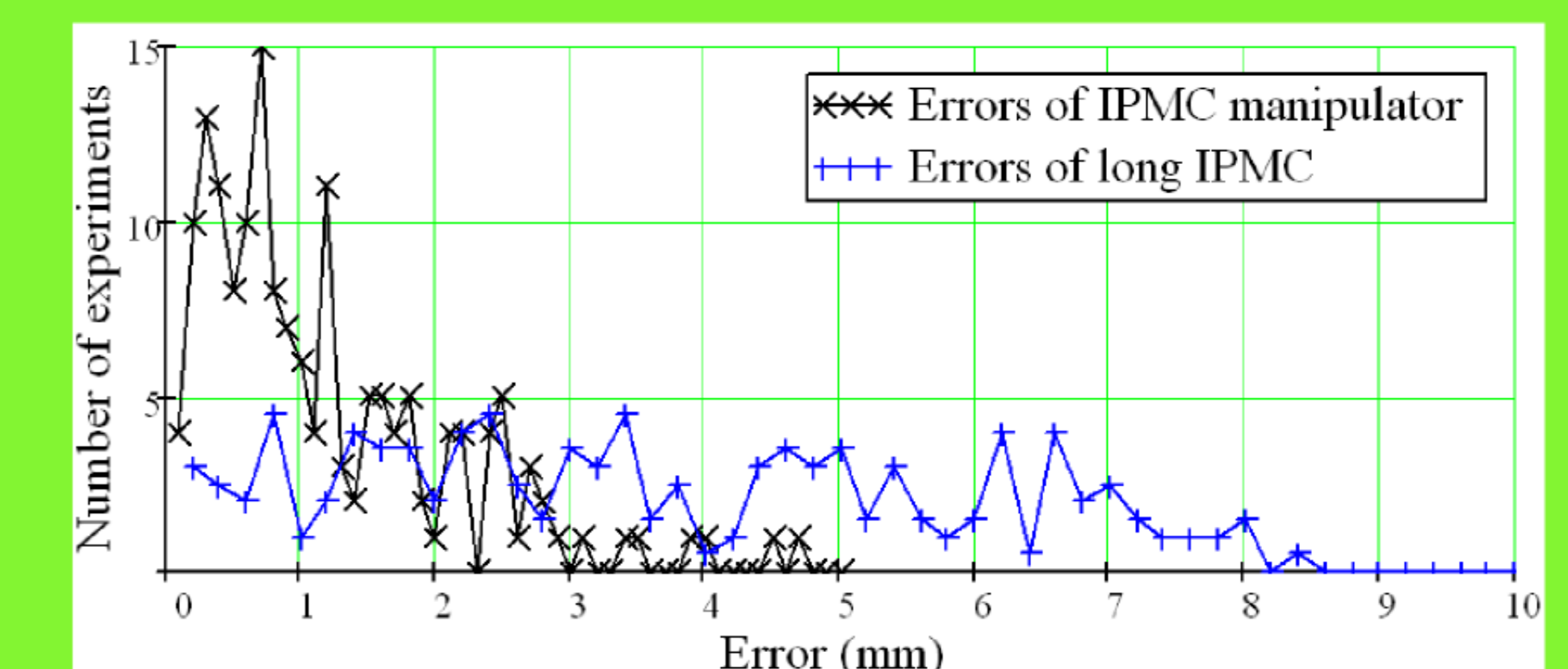

Figure 7. Error distributions of long IPMC and short with extension

5. Conclusions

- Manipulator is more precise than long IPMC.
- Linear relation between input voltage and output angle exists near predicted value.
- Using short IPMC with rigid elongation is more justified than long one without.

6. Acknowledgements

This work is supported by Estonian Science Foundation grant 6765.